

BLACKMER PARTS LIST

PUMP MODEL: TLGLF3C

960426 **PARTS LIST**
Page 1 of 2 **501-D01**

(See Instructions 501-D00 for Installation, Operation and Maintenance)

Section | 501
Effective | August 2006
Replaces | August 2003

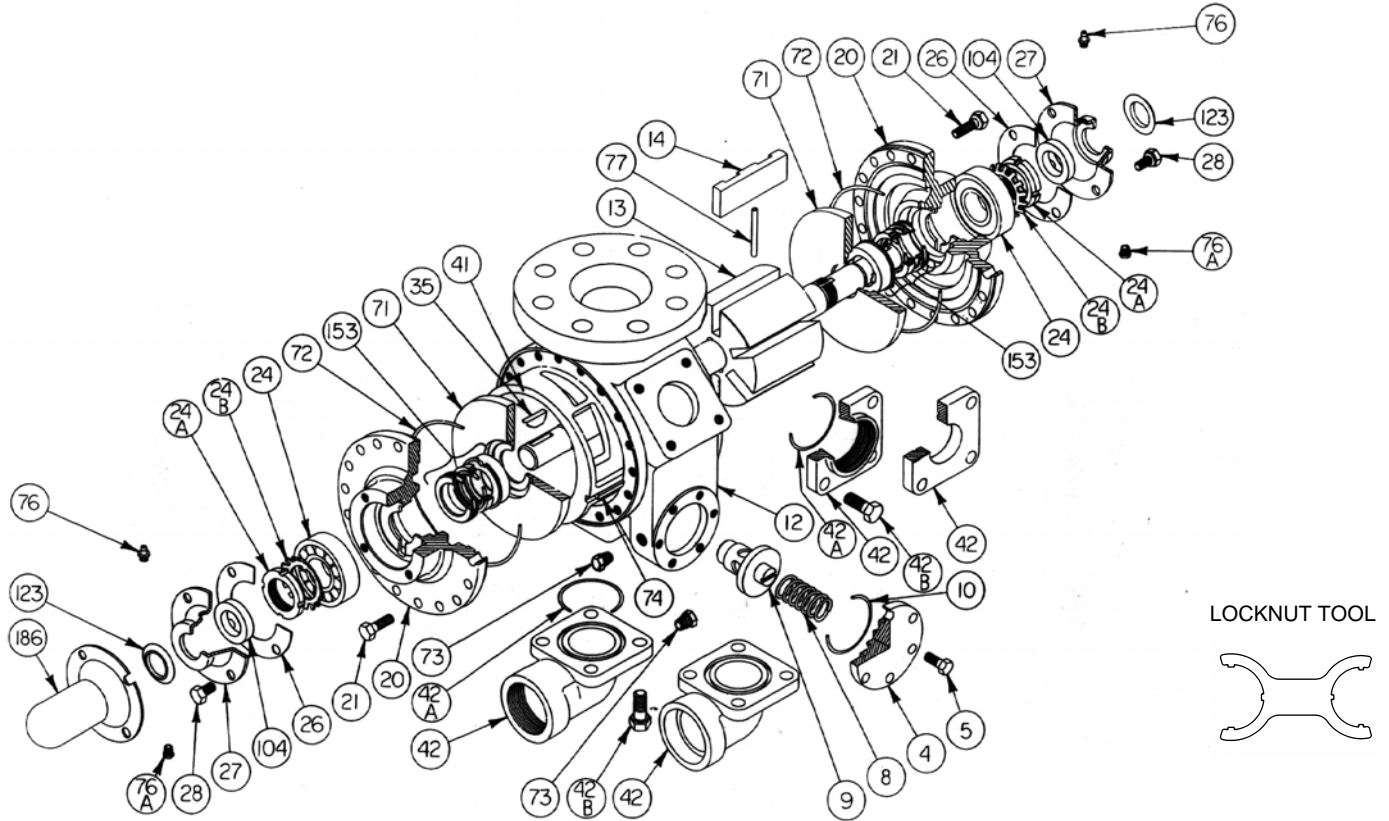

Ref. No.	Description	Parts Per Pump	Part No.	Ref. No.	Description	Parts Per Pump	Part No.
4	Cover - Relief Valve (R/V)	1	415108	42A	O-Ring - Flange 2 1/2" x 2 3/4"	2	¹ 701919
5	Capscrew - R/V Cover	6	920331	42B	O-Ring - Flange 2 5/8" x 2 7/8"	2	^{1,3} 702004
8	Spring - R/V	1	⁴ 471428	42B	Capscrew - Flange, Flanged Elbow	8	920491
9	Valve - R/V (Std.)	1	⁴ 451417	71	Disc	2	¹ 065121
	Valve - R/V (Nickel Plated)		451415	72	O-Ring - Head	2	¹ 711923
10	O-Ring - R/V Cover	1	¹ 701919	73	Gage Plug	2	908198
12	Casing	1	015128	74	Key - Liner	1	² 185193
13	Rotor & Shaft Assembly (Includes Ref. No. 24A & 24B)	1	² 265147	76	Grease Fitting	2	317815
				76A	Grease Relief Fitting	2	701992
14	Vane - Duravane	6	¹ 095132	77	Push Rod	3	¹ 121607
20	Head	2	035132	104	Grease Seal	2	¹ 331918
21	Capscrews - Head	36	920351	123	Dirt Shield	2	¹ 701480
24	Ball Bearing	2	¹ 903156	186	Shaft Protector	1	341601
24A	Locknut - Bearing	2	² 903521	—	Tool - Locknut	—	903091
24B	Lockwasher - Bearing	2	¹ 903522	—	Kit - Maintenance	—	898980
26	Gasket - Bearing Cover	2	¹ 383940	—	Kit - Maintenance with R/V	—	899225
27	Bearing Cover	2	041431	—	Kit - Rebuild	—	899080
28	Capscrews - Bearing Cover	8	920285	—	Kit - Rebuild with R/V	—	899125
35	Key - Shaft	1	¹ 909130				
41	Liner	1	² 185101				
42	Flange - 2" NPT	1-2	652010	¹ Included in Maintenance Kit and Rebuild Kit ² Included in Rebuild Kit ³ Larger O-Ring introduced October 2002 ⁴ Additional parts Included in Kits with R/V			
	Flange - 2" Weld		652024				
	Flanged Elbow - 2" NPT		655100				
	Flanged Elbow - 2" Weld		655109				

Keep this parts list with Installation, Operation and Maintenance Instructions.

MECHANICAL SEAL – NH₃ OR DUAL SERVICE – SNCN (ID Code = QA)

Ref. No.	Part Name	Parts Per Pump	Part No.
153	Mechanical Seal Assembly	2	¹ 334439
153A	Stationary Seat (Steel)	2	**
153B	Seal Face (Carbon)	2	**
153C	Jacket Assembly	2	**
153D	O-Ring - Stationary (Buna-N)	2	711924
153E	O-Ring - Rotating (Buna-N)	2	711918

¹ Included in Maintenance Kit and Rebuild Kit

** NOTE: Mechanical Seal Ref. No. 153 is only sold as a complete assembly. Ref. Nos. 153A, 153B & 153C are not available as separate replacement parts.

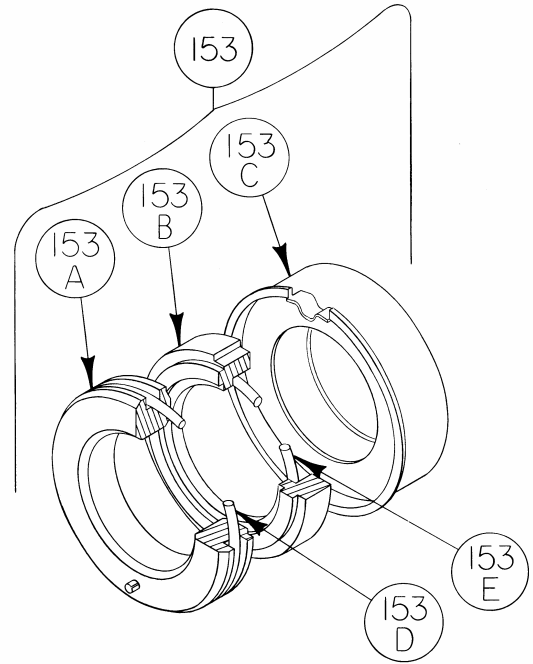

OPTIONAL HYDRAULIC MOTOR ADAPTER PARTS

REF. NO.	PART NAME	PARTS PER PUMP	PART NO.
See Below	Hydraulic Motor Adapter Kit *	See Below	891458
26A	Gasket – Hydraulic Motor Adapter	1	383940
28A	Capscrew – Hydraulic Motor Adapter / Head	4	920369
34	Coupling w/ Setscrew – for 1.25" straight key hyd. motor shaft	1	906967
35	Key – Coupling	1	909184
76	Grease Fitting	1	317815
76A	Grease Relief Fitting	1	701992
135	Hydraulic Motor Adapter – SAE A Flange	1	041828
135A	Capscrew – Adapter / Motor	2	920510

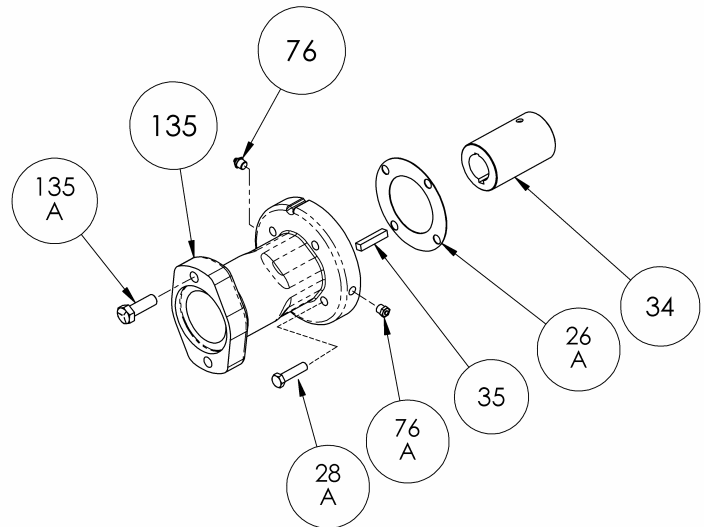

* Hydraulic Motor Adapter Kits shipped prior to Spring 2002 were of a two piece design – refer to page 206-C00.

